

BAYHAM

DIRECT READING TANK CONTENTS GAUGES

Features:

Robust Construction
Leak Proof
Maintenance Free

Applications:

Oil / Water Storage Tanks
Chemical Storage Tanks
Transformer Oil Level Indication
Mobile Tankers and Bowsers

Bayham float operated contents gauges are designed for mounting directly onto tanks to provide continuous indication of tank contents or fluid level. Every gauge incorporates a magnetic coupling through the gauge body preventing fluid leakage into the Dial Chamber.

Bayham contents gauges are of a modular construction with build options to suit a variety of applications including mobile tankers and locomotives. Side mounting and top mounting versions are available with material options to suit the fluid to be measured. Dial sizes from 50mm to 250mm can be supplied with either standard markings in fractions or with custom calibrated dials in engineering units to suit the tank size.

Gauges are available manufactured to suit particular service requirements or standard stock gauges with adjustable length float arms and dials scaled in fractions can be supplied from stock.



Gauge Type	Dim. A	Dim. B	Dim. C	Dim. D	Flange Type
DR 50	9	6	48	92	B9
DR 75	19	6	40	114	B11
DR 90	16.5	6	44	152	B15
DR 150	30	14	44	232	B23
DR 250	32	17	41	337	B34

All Dimensions in mm

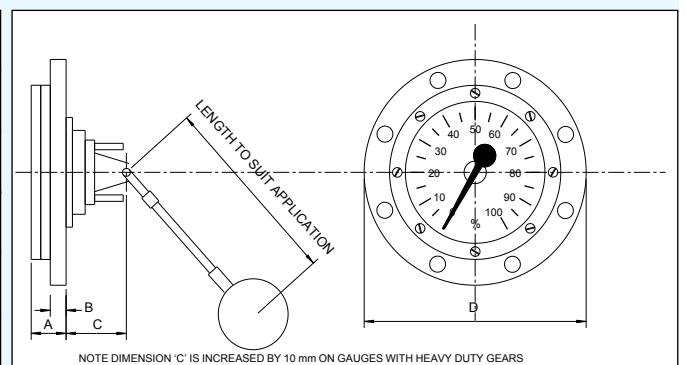

Installation

The most common position to mount the gauge is half way up the side of the tank thus allowing the shortest float arm to be used. Any baffles or internal cross bracing should not interfere with the arc of the float arm travel. Please note that the size, number and position of the gauge flange mounting holes are different for each gauge. Dimensioned drawings are available on request.

We stock mounting pads pre-fitted with studs, nuts, and washers suitable for welding on to steel tanks.

DIRECT READING TANK CONTENTS GAUGES

TANK MOUNTING PAD DETAILS

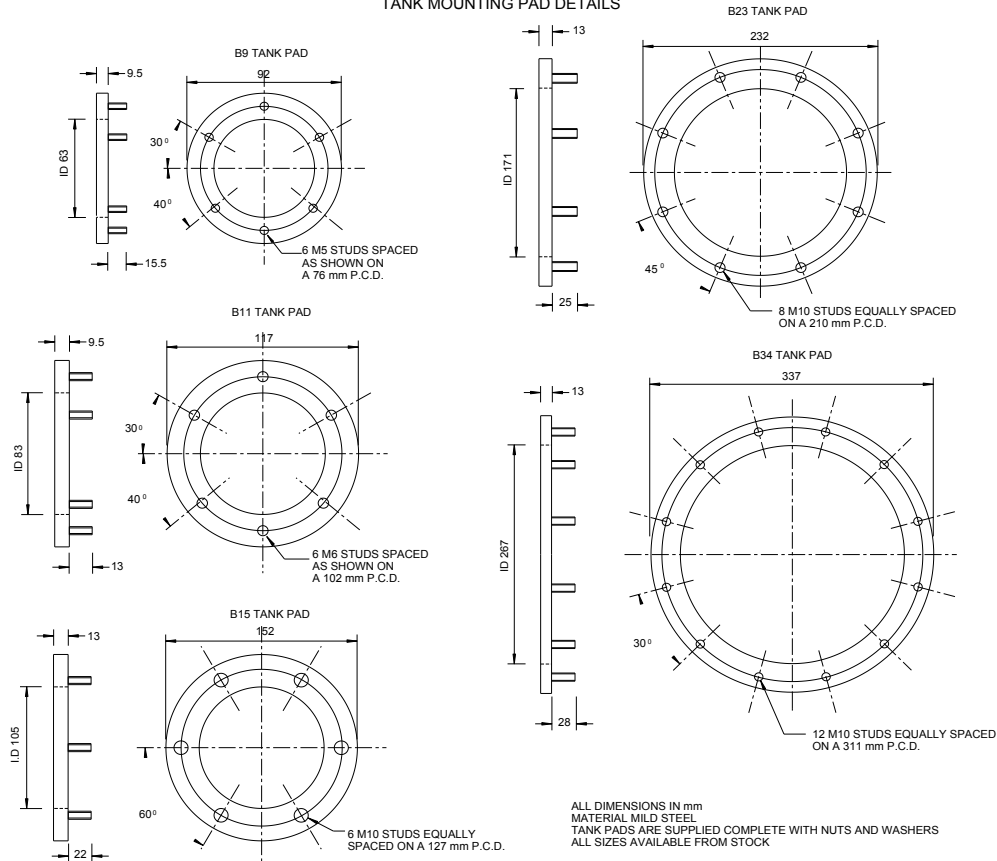

Information required:

1. Gauge Type
2. Tank Dimensions
3. Mounting Position of Gauge
4. Fluid Details
5. Operating Conditions
6. Dial Calibration Units i.e. fractions, %, litres, etc.
7. Whether Static or Mobile application
8. Tank Slope Angle, if any

Please contact our sales department for tank pad mounting instructions. Tank pads are available from stock and may be shipped within 24 hours if required.

We have many years of experience manufacturing tank gauges for a wide variety of applications. Please contact us for further information or guidance on specifying the correct gauge to suit your requirements.

TANK MOUNTING VARIATIONS

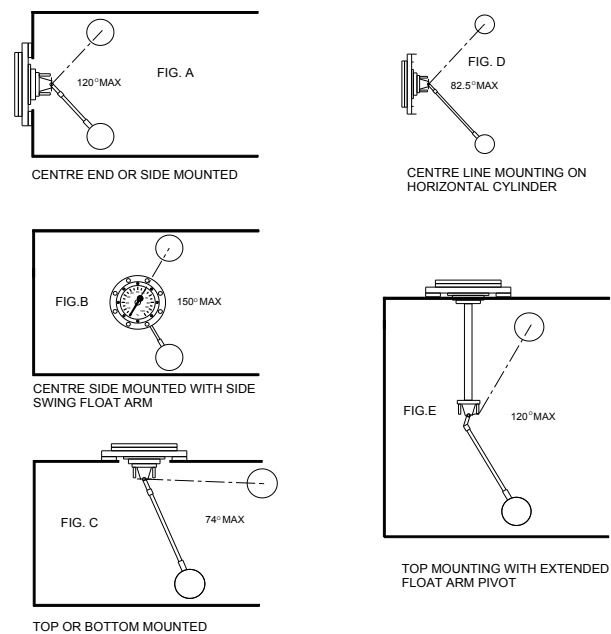

BAYHAM LTD.

Bayham Ltd. Rutherford Road Basingstoke Hampshire UK RG24 8PG
Tel: +44 (0) 1256 464911 Fax: +44 (0) 1256 464366